



DCNORRIS

CT1









COMMERCIAL SOUS VIDE COOK TANK



SMALL COMPACT DESIGN

SIMPLY CONNECT TO ELECTRICS & COOK!

The CT-1 has been developed specifically with the small-scale food manufacturers, food service or restaurant in mind. The 250 litre (water capacity) user-friendly electric system is simple to install and operate, and can easily fit into any size kitchen area, whilst producing delicious slow-cooked foods. The CT-1 is also designed to reduce carbon footprint giving optimum performance whilst using the minimum amount of energy and water!

-  Improve flavour and texture
-  Nutrients and vitamins 'locked-in'
-  Remove risk of over-cooking and 'drying out'
-  Retain product integrity
-  Save 10-20% from increased yields
-  Accurate temperature control
-  Increase shelf life
-  Maximum water savings - variable water levels



'Sous Vide Cooking is the single greatest advancement in cooking technology in decades.'







Heston Blumenthal, Three Michelin Star Chef

WHAT IS SOUS VIDE?

Sous Vide involves cooking food under vacuum in airtight plastic pouches submerged in a Cook Tank/ Water Bath. Products are slow cooked in the Cook Tank which is held at a precisely controlled low temperature, ensuring foods are cooked evenly and to perfection every time.

The Sous Vide method of cooking eliminates guesswork and allows you to cook foods with incomparable taste and texture; perfectly cooked steak, tender chicken breasts and ribs with the meat falling off the bone. Products can also be cooked in a sauce or marinade giving food producers additional recipe choices.

THE PROCESS

-  Place pre-packed pouches into lasered baskets in the Cook Tank.
-  Set target temperatures and times.
-  Place temperature probe (sealed within the bag) in the core of one of the products, and start the system.
-  Hot water is recirculated ensuring even heat distribution (no 'hot spots').
-  A timer starts when the product reaches its core temperature.
-  The tank is drained after cooking and is replenished with ambient water, which is chilled to just above freezing.
-  This combination of vacuum packing, slow cooking and rapid cooling retards bacterial growth, locks in freshness and provides up to 45 days chilled shelf life.



CT-1

Slow cooking at a low temperature improves texture, intensifies the flavour & preserves nutritional quality.

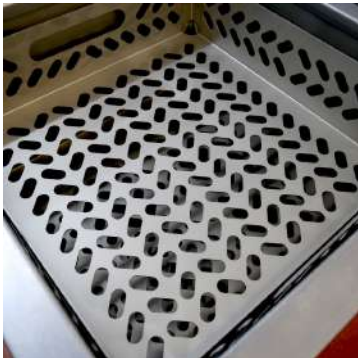

- Full automated operation
- Electric heating
- Integral heat exchanger and pipework arrangement
- Temperature probes (tank mounted & hand held)
- Mitsubishi HMI colour touch screen
- DCN Virtual Chart Recorder Software (optional extra)
- Slow overnight cooking
- Power failure memory retention

features

Meat	Poultry	Fish
Beef	Chicken	Cod Fillets
BBQ Ribs	Turkey	Salmon
Beef Burgers	Duck	Whole Trout
Lamb	Pheasant	Sea Bass
Pork	Quail	Haddock
Ham		Halibut
Goat		Seafood Chowder



products

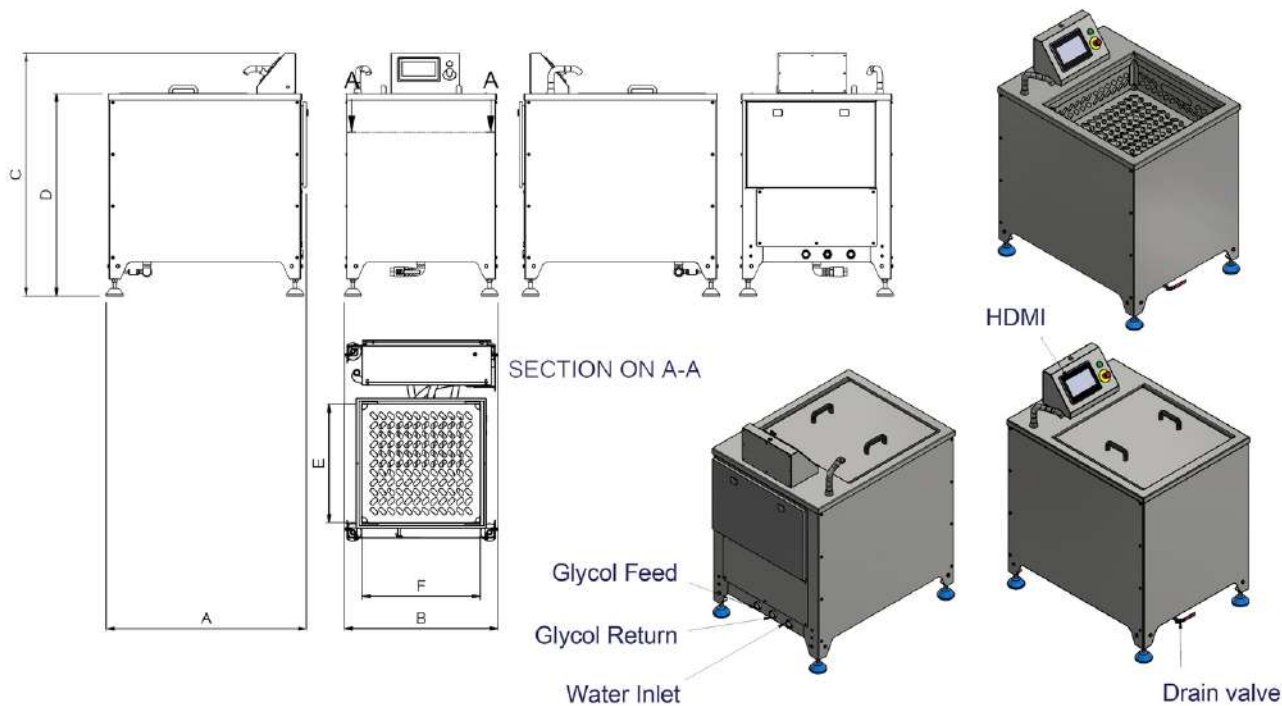

A Overall Depth (mm)	B Overall Width (mm)	C Overall Height (mm)	D Tank Height (mm)	E Tank Depth (mm)	F Tank Width (mm)
993	716	1128	940	550	550

Tank Water Capacity (ltr)	Product Capacity (kg)	Electric (Kw)	No. of Baskets
250	15	9	3

Manual lift out baskets 600 x 600 x 150mm deep.
Control panel can be modified to suit multiple machines

Service Requirements	
Electrical	400v 3ph 50Hz Neutral + Earth
Current	25A
Mains Water	50 ltrs/min @ 2 Bar (Tank initial fill) - 1" BSP Female
Chilled Water/Glycol	50 ltrs/min at 0/+1 °C Customer supply
Drain	capable of removing up to 75 ltrs/min @ 99°C (Max) - 1" BSP Female

technical data



DCN

DC Norris & Company Ltd

Sand Road Industrial Estate
Great Gransden
Nr. Sandy
Bedfordshire
SG19 3AH
United Kingdom

T: +44 (0)1767 677515

F: +44 (0)1767 677851

E: mail@dcnorris.com

www.dcnorris.com

food processing innovation