

TRANSFER /HOLDING VESSELS

DCN Transfer Vessels are ideal for the vacuum, pressure filling and transfer of hot or cold liquid product. Made from 304 grade stainless steel, vessels are custom made to customer requirements.

Smaller units are mounted on two fixed and two swivel castors, allowing the tank to also serve as a mobile holding vessel. Larger units are mounted on legs with provision for forklift truck entry for lifting and transporting.

Features

- Insulated / jacketed
- Agitated or non-agitated models available
- Hinged lid
- Hygienic butterfly valve (size to suit customer requirements)
- Stainless steel grade 304 as standard
- 316 contact parts available on request
- Designed to PD5500:2003
- Working pressure 0.5 bar (or to suit customer requirements)
- Tested to 25" vacuum

Options

- Mechanically driven mechanical agitator
- Air powered auger-style agitation
- Compressed air heater arrangement



Auger-style agitation



Standard sizes - 300-600 litres.
Larger sizes up to 1000 litres available upon request.

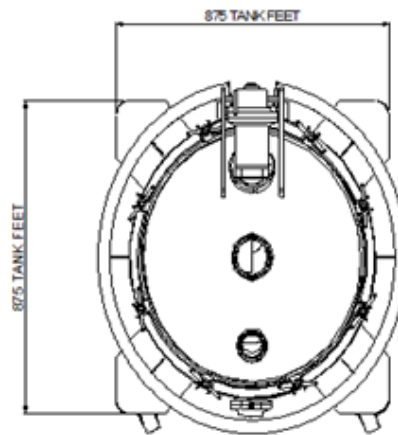
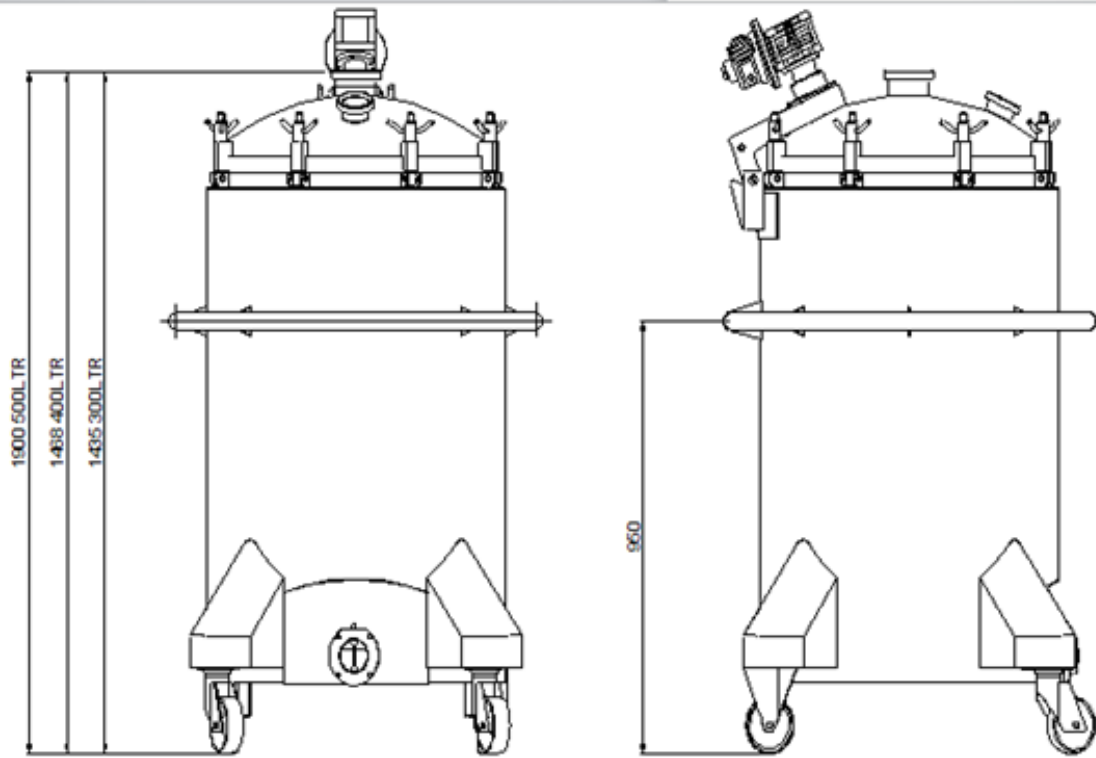

| | 300 litre | 400 litre | 500 litre |
|-------------|-----------|-----------|-----------|
| Height (mm) | 1435 | 1468 | 1900 |

technical data

