



DCNORRIS



MODEL 160 CAN OPENER

Throughput of 200-300 cans an hour

The model 160 pneumatically operated can-opener is ideal for small quantities and is adaptable for a range of can sizes and shapes. With a capable throughput of 200-300 cans an hour, removing the lid in one easy cut, the can-opener can greatly improve production times.

Option to upgrade to semi-automatic mid-range line, ideal for larger batches.

Features

- Adjustable for different sized cans - 60 mm to 230 mm diameter
- Manufactured with heavy duty hygienic glass bead blasted stainless steel
- Two handed start
- Fully enclosed blade
- No metal chips
- Interchangeable heads
- Height block kit included
- Quick release heads for easy cleaning
- Manufactured in the UK

Available Options

- Support Stand
- Infeed Table
- Can Rinse / Air Blast Water Removal Unit
- Product Chute
- Drop-In Mesh
- Can Crushing System
- Magnetic Lid Removal System
- Vibratory Conveyor

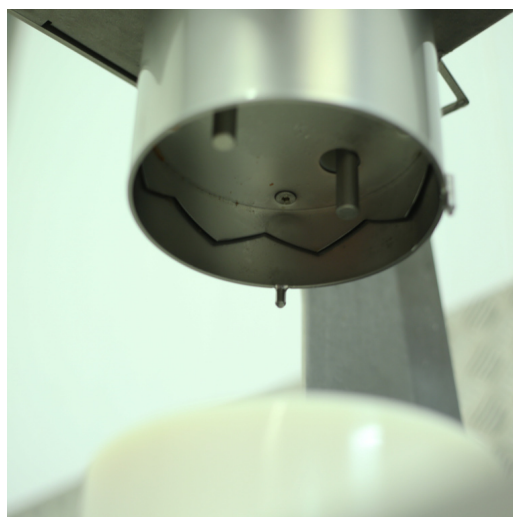



DCNORRIS

technical data

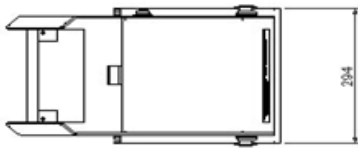
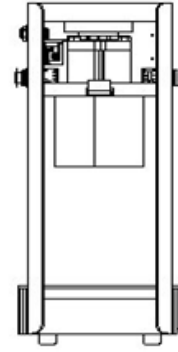
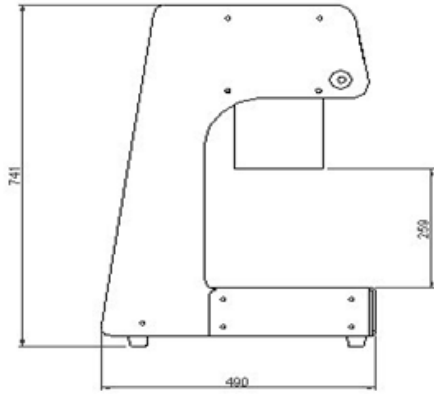

Height (mm)	Width (mm)	Length (mm)	Weight (kg)
741	294	490	36

	Requirement	Connection
Air	6 BAR	12mm



DC Norris & Company Ltd
Sand Road Industrial Estate, Great Gransden, Nr. Sandy, Bedfordshire,
SG19 3AH, United Kingdom

T: +44 (0)1767 677515 | E: info@dcnorris.com | W: www.dcnorris.com