



www.dcnorris.com

STEAM JACKETED KETTLE

inclined agitator

DCN direct steam kettles are designed for the cooking and/or mixing of a wide range of food products, including soups, casseroles, sauces and preserves. With bespoke designs to suit each customer's individual requirements; kettles are available with a huge range of features and accessories. Kettles can be integrated into existing processes by utilising the range of outlet options that can be fitted to the standard outlet in the base of the kettle. These include manual or automatic ball valves and EHEDG certified, air operated flush fitting drop down valves.

Kettle Features

- ⇒ Standard sizes from 300 to 1500 litres (custom sizes made to order)
- ⇒ Inclined scraping type agitator which has patented scoop-type scraper shovels with replaceable, heat resistant, food approved plastic blades
- ⇒ Steam jacket operates up to 7 bar – supplied from two steam connections on either side of kettle to provide even heat distribution
- ⇒ Kettles manufactured in stainless steel grade 316 for all food contact parts and type 304 for all other parts
- ⇒ Kettles are available to either PD5500 Cat 3 or to ASME VIII Div 1
- ⇒ Split Jacket available for cooking small batches
- ⇒ Supported on three or four legs (depending on size)
- ⇒ Insulated and stainless steel sheathed
- ⇒ Standard internal sanitary finish of 180 grit
- ⇒ External surfaces have a semi-deluxe buff or bead blast finish (or to customer's specification)

Options:

- * Jet Cook Steam Infusion System
- * Steam Injectors
- * High Shear Mixer
- * Tilt Out Agitator
- * Recipe Management System
- * Virtual Chart Recorder
- * Load Cells
- * Braising Bar
- * Drop In Sieve
- * Outlet Valves
- * Access Platform



TECHNICAL DATA

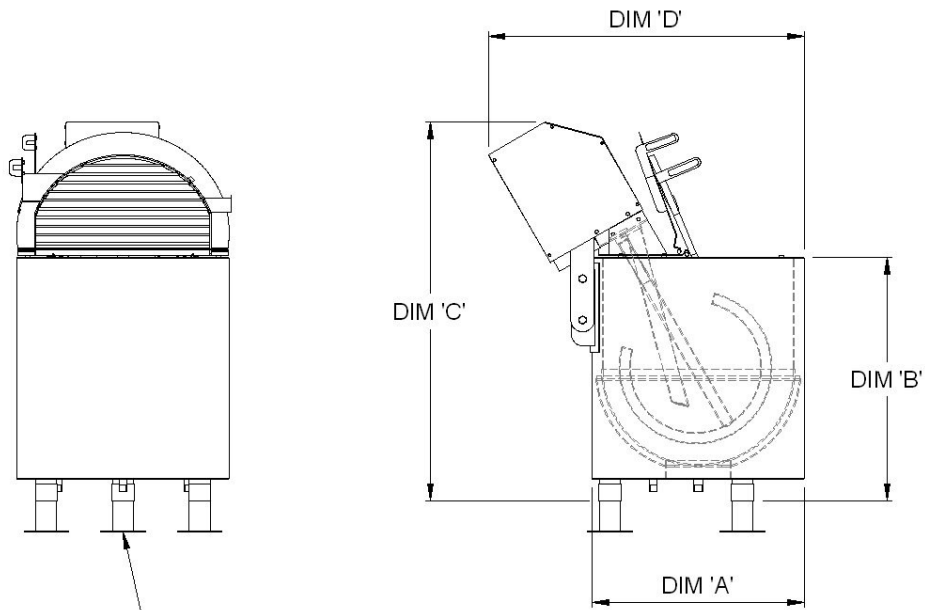

CAN BE ADJUSTABLE FOOT, LOAD CELL
PLATE OR TO SUIT CUSTOMER INSTALLATION

Kettle Size (ltrs)	Kettle Diam Dim A (mm)	Kettle Height Dim B (mm)	Overall Kettle Height Dim C (mm)	Kettle Depth Dim D (mm)	Connection Sizes (inches)
300	900	1030	1602	1339	1
500	1020	1177	1776	1507	1
750	1222	1235	1912	1650	1 ½
1000	1332	1394	2102	1785	1 ½
1500	1478	1588	2271	1918	1 ½



D C Norris & Company Ltd

Industrial Estate, Sand Road, Great Gransden

Nr Sandy, Bedfordshire, SG19 3AH

United Kingdom

t: +44 (0)1767 677515

f: +4 4(0)1767 677851

e: mail@dcnorris.com



www.dcnorris.com